

Electronics: Why do we care? Two main reasons

- Every instrumental measurement involves a *transduction* step that converts a chemical/physical response into an electrical signal.
 - Need to ensure that signal is a good reflection of the response

- Many instruments are now interfaced with computers
 - Need to ensure that analog and digital components communicate effectively

Signal Transduction: Data Domains

- Information can be “stored” or communicated in several ways

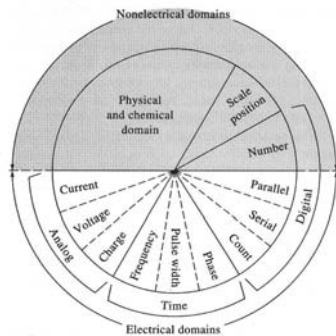

Figure 1-2 Data domains map. The upper (shaded) half of the map comprises nonelectrical domains. The bottom half is made up of electrical domains. Note that the digital domain spans both electrical and nonelectrical domains.

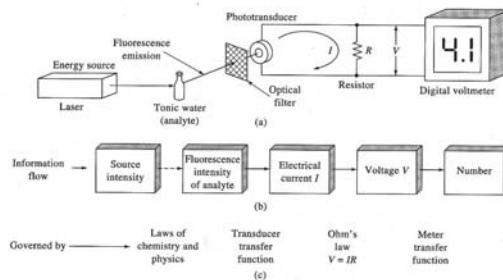

Figure 1-3 A block diagram of a fluorometer showing (a) a general diagram of the instrument, (b) a diagrammatic representation of the flow of information through various data domains in the instrument, and (c) the rules governing the data domain transformations during the measurement process.

Golden Rules of Circuits: Dust off the physics!

- Ohm's Law:
 - Voltage drop across a resistor is proportional to the flow of electrons (current) through the resistor and the magnitude of the resistance

$$E = IR$$

- Kirchoff's Laws:
 - All of the currents in and out of a node must sum to zero.
 - The voltages around a loop must sum to zero
- Power Dissipation:
 - The power dissipated in a circuit is related to the current and the resistance of the circuit

$$P = IE = I^2R$$

Basic Circuits: Passive Components

- Two main types: Resistors and Capacitors



- Resistance in circuits
 - Series:

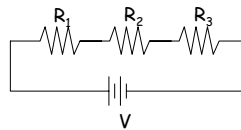

Parallel:

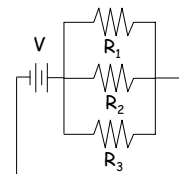

Capacitance: Charge Storage

- Store charge by applying potential (Voltage) across a dielectric.

$$C = Q/V \text{ (C has units of Farads)}$$

- Capacitors are affected by *changing* currents and voltages

$$\frac{dQ}{dt} = I = C \frac{dV}{dt}$$

- Capacitors in series and parallel:

- Series:

- Parallel:

Important Passive Component Combinations

- Voltage Divider

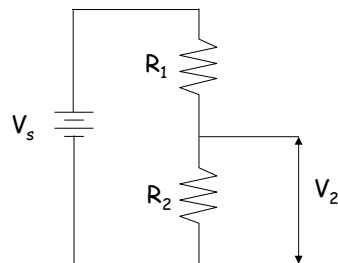

Important Passive Component Combinations

- Series RC Circuit

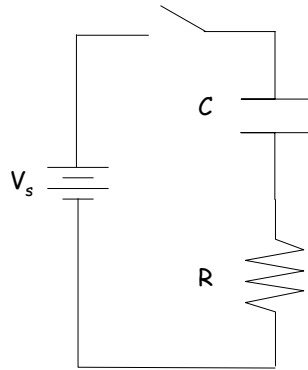

Semiconductor Devices

- Diodes
 - greater conductivity in one direction
 - Made by coupling n -type and p -type semiconductors

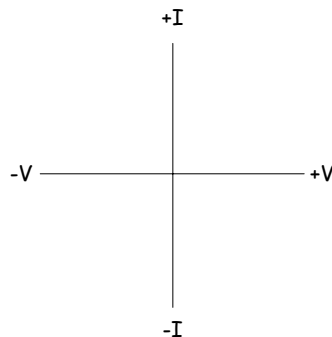
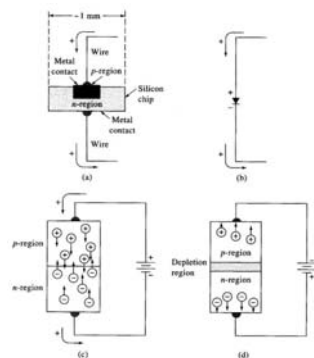

- Transistors
 - Combinations of diode junctions
 - Useful for switching and amplification

Diodes

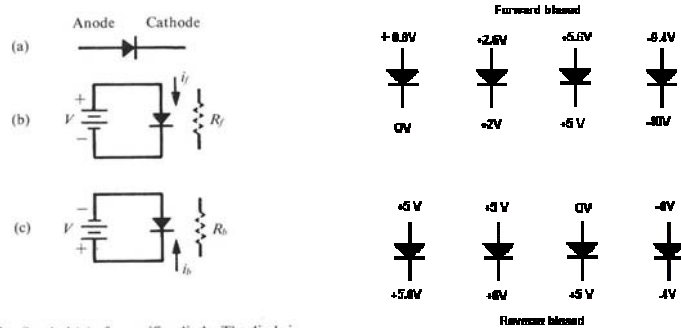
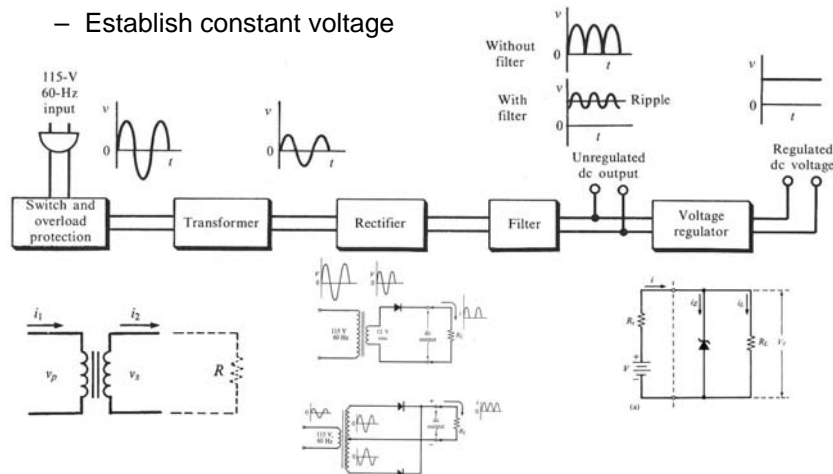

Fig. 3-7. Symbol (a) of a rectifier diode. The diode is shown forward biased in (b) and reverse biased in (c). The forward resistance R_f is always much less than the backward resistance R_b .



Power Supplies

- Convert AC to DC to operate semiconductor devices
- Two functions
 - Remove oscillation in voltage
 - Establish constant voltage



Operational Amplifiers

- **Solid-state device**
 - combination of transistors, diodes, resistors, capacitors on a chip
 - many, many applications!
- **General Characteristics:**

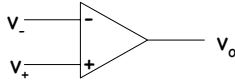

- All potentials are relative to **circuit common**
- Response: $v_o = A(v_+ - v_-)$
- Ideal characteristics:
 - Large open loop gain (A)
 - High input impedance: no current through the op-amp!
 - Low output impedance:

Op-Amps

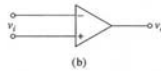
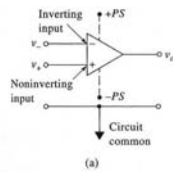

Figure 3-2 Symbols for operational amplifiers. More detail than usual is provided in (a). Note that the two input potentials v_- and v_+ as well as the output potential are measured with respect to the circuit common, which is usually at or near earth ground potential. (b) The usual way of representing an operational amplifier in circuit diagrams. (c) Representation of typical commercial 8-pin operational amplifier.

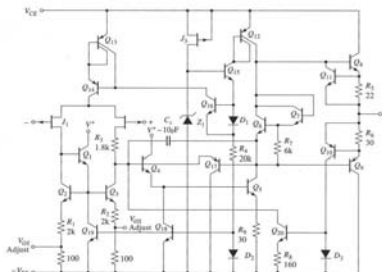
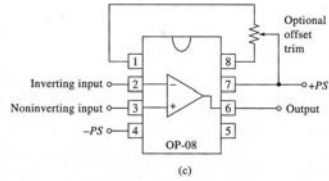
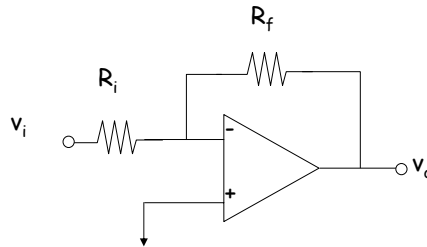

Figure 3-3 Circuit design of a typical operational amplifier. (Courtesy of National Semiconductor Corporation)

Op-Amp Circuit Analysis

- Remember A is huge (10^4 to 10^6 or larger)
- AND no current through the op-amp!



Op-Amp Circuit Analysis, II

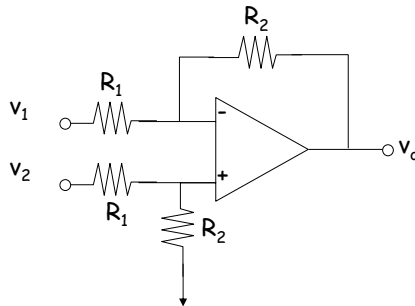

Op-Amp Possibilities (only a few)

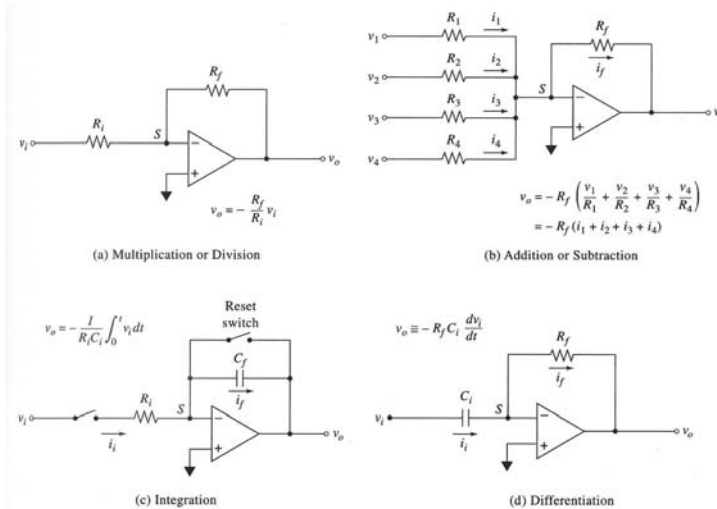
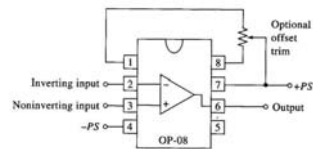

Figure 3-14 Mathematical operations with operational amplifiers.

Practical Considerations

- Common wiring pattern



- Power supply connections (+/- 15 VDC)
- “Trim” connections
 - offset voltage compensation
- Response time considerations:
 - Slew Rate

Communications between an Instrument and a Computer: Analog Regime to Digital Regime

- In order for information to be transferred an analog to digital conversion must occur.
 - Analog: continuous in magnitude and time
 - Digital: discontinuous, finite number of values, “quantized”
- Centered on binary logic
 - only two states: “on” and “off”
 - Example: 8-bit binary number: 10010110
 - Least Significant Bit (LSB):

Counting with Flip-Flop Logic

- Flip-flop: Only changes output when the input changes from 1 to 0 (only one direction)

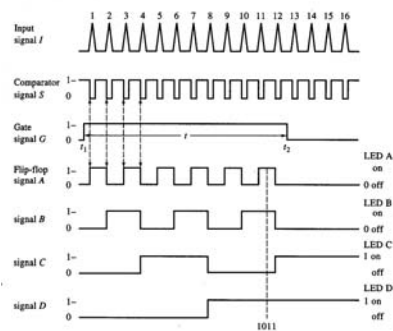
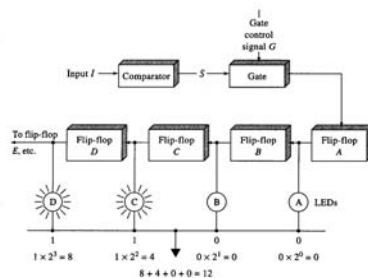

A/D and D/A Conversion

- From instrument to computer:
A/D Conversion

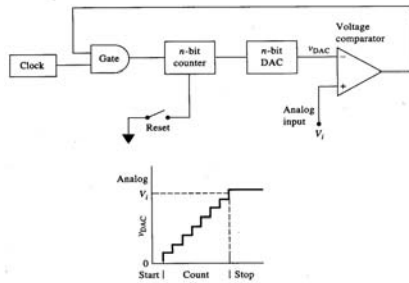

Figure 4-8 A staircase analog-to-digital converter (ADC).

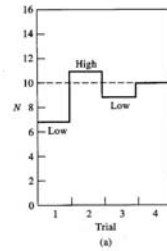
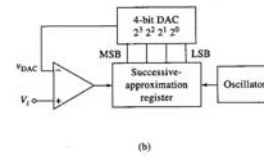

Figure 4-9 Successive-approximation ADC: (a) output of the DAC during the conversion process, (b) block diagram of the ADC.



A/D and D/A Conversion

- From computer to instrument:
D/A Conversion

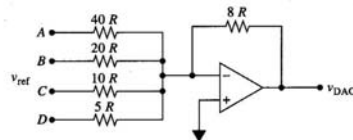

Figure 4-7 A 4-bit digital-to-analog (DAC) converter. Here A , B , C , and D are $+5\text{ V}$ for logic state 1 and are 0 V for logic state 0.

- Resolution Considerations
 - What if we need to encode (or decode) a $\pm 2\text{V}$ signal with resolution of 1mV ? How many bits do we need?

Considerations of Analog↔Digital Conversion

- Sampling Considerations: Need the digital signal to be a good representation of real life.
 - Counting
 - Timing
 - A/D or D/A conversion

- Aliasing

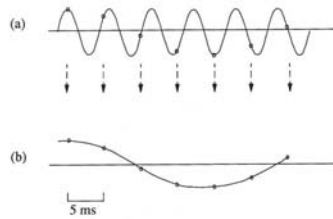

Figure 2-28. (a) Aliasing of 175 Hz to 25 Hz in a 175-Hz sine wave is shown. (b) Samples taken at 200 Hz. When the sample points are connected, the 25-Hz alias is revealed.

- Rule of thumb: Signals should be sampled at a rate at least twice the highest frequency component of the signal. (Nyquist Theorem)