

LC Techniques

- LC covers a wide range of analytes and interactions
 - Very similar instrument components
 - All have liquid mobile phase
 - solution of analyte in a solvent
 - equilibrium occurs between solvent in mobile phase and solid stationary phase

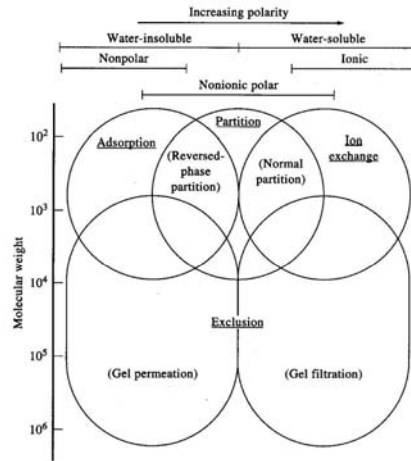

Figure 28-1 Applications of liquid chromatography. (From D. L. Saunders, in *Chromatography*, 3rd ed., E. Heftmann, Ed., p. 81. New York: Van Nostrand Reinhold, 1975. With permission.)

Bandshapes in LC

- Subject to the same general broadening considerations as any chromatography technique
 - Multipaths
 - Longitudinal
 - Mass Transfer
- Particle size plays a major role
- Extracolumn Broadening
- Sample Size Effects

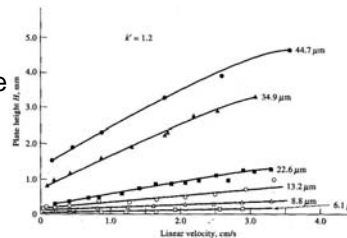

Figure 28-2 Effect of particle size of packing and flow rate upon plate height H in liquid chromatography. Column dimensions: 30 cm \times 2.4 mm. Solute: *N,N*-diethyl-*n*-aminobenzene. Mobile phase: mixture of hexane, methylene chloride, isopropyl alcohol. (From R. E. Meier, *J. Chromatogr. Sci.*, 1973, 11, 92. With permission.)

LC Instruments

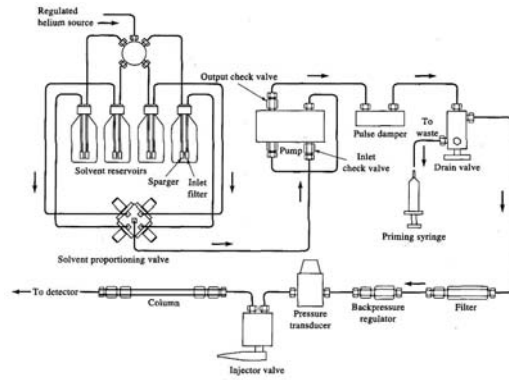

Figure 28-4 Schematic of an apparatus for HPLC. (Courtesy of Perkin-Elmer Corporation, Norwalk, CT)

- Solvent purification - Filtering/Degassing
- Complexity of pumping system depends on sample requirements
 - Isocratic elution
 - Gradient Elution

LC Pumps

- Pump Requirements:
 - High pressure
 - Pulse Free
 - Variable flow rates
 - ~0.1 to 10 mL/min
 - Reproducible flow rates
 - Stable components
- Most common: Reciprocating Pump
 - Pulsed, but high pressure capability
- Others:
 - Syringe (displacement) pumps
 - (+) Pulse free, (-) low volume, (-) low pressure, (-) single solvent
 - Pneumatic Pumps
 - (+) Pulse free, (-) no gradient capability, (-) low pressure

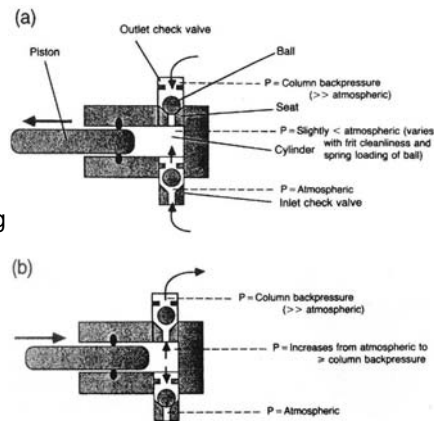

Figure 13.5 Operation of piston and check valve reciprocating pump: (a) suction stroke and (b) exhaust stroke. (Katz et al., used with permission.)

Sample Introduction

- Injection Loop...Autosampler
 - Reproducibility!

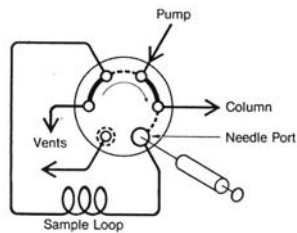
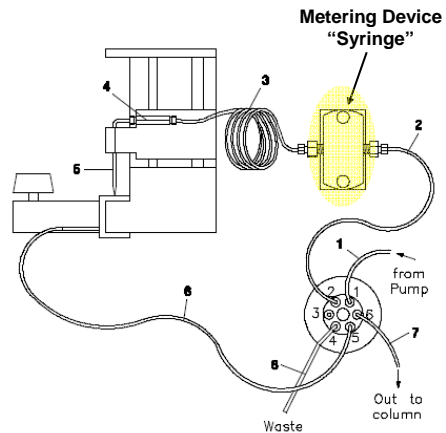

Figure 13.6 (a) Diagram of operation and (b) photo of two-position rotary injection valve. (Katz et al., used with permission.)



HP 1050 Autosampler

LC Columns

- Generally stainless steel a few mm in diameter and 10-30 cm long
- Packed with two types of stationary phase support
 - Pellicular particles
 - Porous particles
- Column life is extended with the use of guard columns
 - sacrificial
 - packed similarly to analytical column

LC Detectors

- Same demands as GC detectors
 - sensitivity, universally applicable, etc.
- No (truly) universal detectors exist!
 - Bulk Property vs Solute Property:

Absorbance Detectors

- Small volume cells
 - but high concentration!
- Why Z-shaped?
- Often double-beam
- D₂ or filament sources
- Filter or monochromator-based
- Single or multi-channel detectors
- UV-Vis most common, but IR is also used

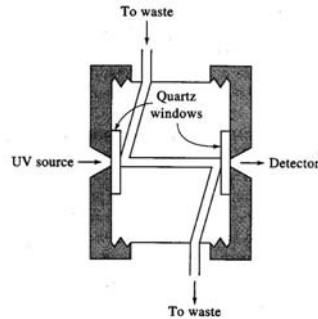

Figure 28-9 Ultraviolet detector cell for HPLC.

LC Detectors

Fluorescence Detectors

- Similar optics, but collect light at 90° to excitation.
- Not universally applicable directly, but can be “tweaked”
 - Chemical Derivatization
 - Pre- vs. Post- column derivatization.
 - Indirect Detection

Electrochemical Detectors

- Most common type is amperometric detector
 - Potential is applied to working electrode to drive redox process
 - Measured current is related to concentration
- Applicable to a wide range of compounds and organic functional groups
- Sensitive, simple, cheap?
- Susceptible to electrode fouling

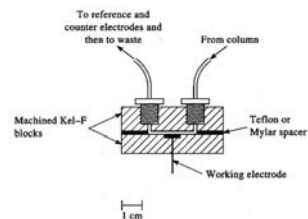

Figure 28-13 Amperometric thin-layer detector cell for HPLC.

LC Detectors

Refractive Index Detectors

- Monitors refractive index of the solution as it exits the column
- Anything that changes the refractive index (like an analyte) will result in a peak
- More universal than most LC detectors (bulk property detector)
- BUT not as sensitive, highly susceptible to temperature fluctuation

Evaporative Light Scattering Detectors

- As sample leaves column, it is nebulized and solvent evaporated to produce small particles of sample.
- Laser light is scattered off the particles.
 - More analyte → More particles → More scatter
- Fairly universal and more sensitive than RI!

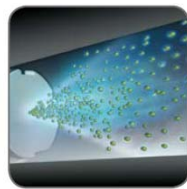

1. Nebulization

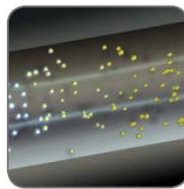

2. Evaporation

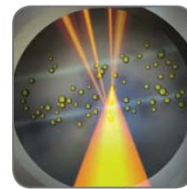

3. Detection

elsd.com

LC Detectors

Mass Spectrometric Detectors:

- Interfacing challenges

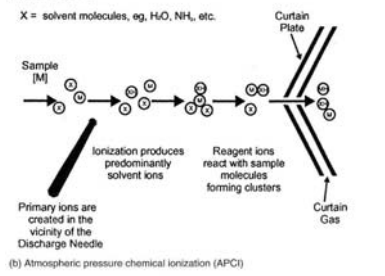
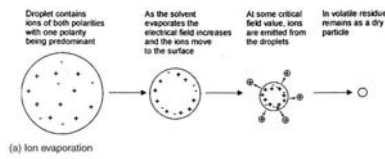

Figure 13.15 LC-MS interface ionization mechanism diagrams. (a) coulomb explosion in ESI droplets and (b) reactions leading to molecular ion in APCI. (Adapted with permission from Applied Biosystems/MDS Sciecs.)

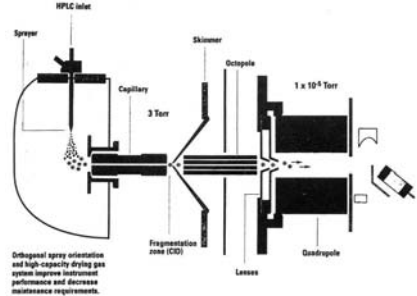

Figure 13.16 Diagram of orthogonal electrospray LC-MS interface. (Adapted with permission from Agilent Inc.)

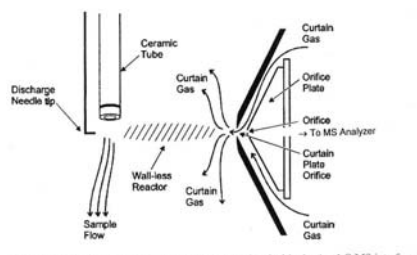

Figure 13.17 Diagram of atmospheric pressure chemical ionization LC-MS interface. (Adapted with permission from Applied Biosystems/MDS Sciecs.)

Separation Schemes: Combinations of Mobile Phase/Analyte/Stationary Phase

Partition Chromatography

- Separation results from intermolecular interactions between analyte and mobile/stationary phase
 - Hydrophobic, dipole-dipole, H-bonding, ionic...

- Typically use bonded-phase packing

– Derivatized silica

– Hydrolyze silica in HCl

– React silanol groups with derivatizing agents

– Remove unreacted silanol by endcapping

- prevents unwanted adsorption/interaction

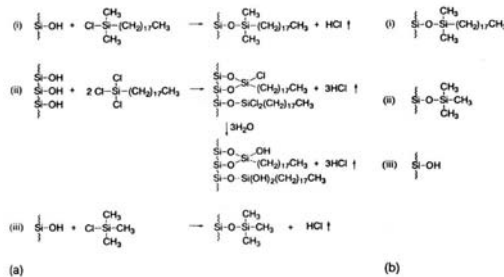

Figure 13.1 Types of ODS-silica HPLC stationary phases: (a) i, synthesis of monomeric C18; ii, synthesis of polymeric C18; iii, endcapping process; and (b) i, monomeric C18 ligand; ii, encapped silanol; and iii, residual silanol. (Cazes, used with permission.)

Separation Schemes

Normal Phase versus Reverse Phase

- Controls elution order and (in part) separation quality
- Normal Phase:** *Polar* stationary phase, *less polar* mobile phase
- Reverse Phase:** *Nonpolar* stationary phase, *more polar* mobile phase

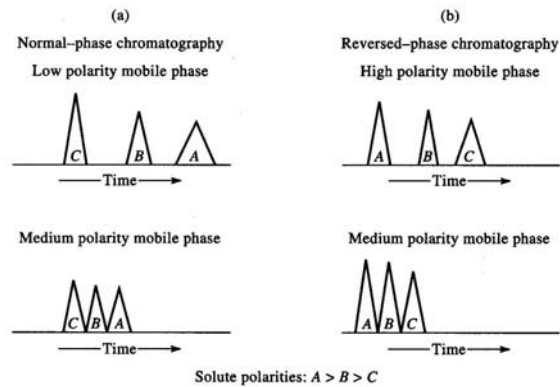

Figure 28-14 The relationship between polarity and elution times for normal-phase and reversed-phase chromatography.

Separation Schemes

- Most modern separations are done using reverse-phase column
 - spherical particles coated with alkane chains
 - varying chain lengths changes polarity
 - Behaves much like a "liquid" hydrocarbon coating

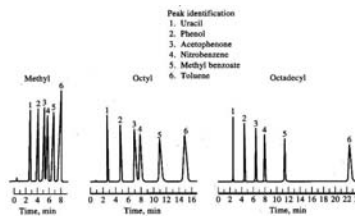

Figure 28-15 Effect of chain length on performance of reversed-phase siloxane columns packed with 5- μ m particles. Mobile phase: 50/50 methanol/water. Flow rate: 1.0 mL/min.

- Possible to manipulate the quality of the separation (N , k' , α) by changing solvent composition OR by modifying analyte characteristics
 - Derivatization
 - change polarity
 - change sensitivity
 - change selectivity
 - Ion-Pairing
 - Ion-pair is retained on column
 - Anions - Tetraalkylammonium salts
- Chiral Separations: "Chiral" stationary phase

Separation Schemes

Adsorption Chromatography:

- Direct interaction between analyte and solid stationary phase (silica, alumina)
- Normal phase-like separation
 - Nonpolar mobile phase

Size-Exclusion Chromatography:

- Separation is a result of "trapping" of molecules in the pores of the packing material
 - Very large molecules can't get into the pores - unretained
 - Very small molecules get hung up in to pores for a long time - most retained - longest retention time
- Separation is based exclusively on size (shape)
 - No physical interaction occurs (ideally)
 - Use "inert" stationary phases
 - silica, polymer beads
- Pore size determines range of analytes that can be separated
 - If two different analytes are too large to fit in the pores, they will co-elute
 - *Exclusion limit*
 - If two analytes are small enough to freely move into the pores, they will also co-elute
 - *Permeation limit*
- Result is rapid separation, long column life, but need range of sizes (molecular weights)

Separation Schemes

Ion Exchange Chromatography:

- Use ionic stationary phase
 - ions separated on the basis of their tendency to displace counterions adsorbed on stationary phase
 - Depends on charge, hydration, "solubility"...
- Anionic sulfonated styrene/divinylbenzene stationary phases: Typically H^+ is counterion
 - used for cation separation
- Cationic stationary phases are usually quaternary amines

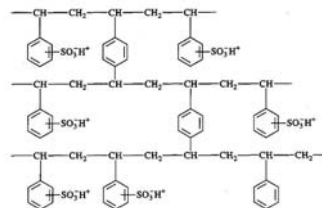

Figure 28-21 Structure of a cross-linked polystyrene ion-exchange resin. Similar resins are used in which the $-SO_3H^+$ group is replaced by $-COO^-H^+$, $-NH_3^+OH^-$, and $-N(CH_3)_3^+OH^-$ groups.

Detection in ion chromatography

- **Conductivity** seems like a good idea!
 - BUT large background
 - Minimize background by using suppressor column
 - post-separation process
 - Converts eluent (not analyte) ions into neutrals
 - typically an acid-base reaction...results in low background conductivity
 - Cation Separations: $H^+ + Cl^- + Resin^+OH^- \rightarrow Resin^+Cl^- + H_2O$
 - Anion Separation: $HCO_3^- + Na^+ + Resin^+H^+ \rightarrow Resin^+Na^+ + H_2CO_3$
- Other modes work, too
 - Photometric
 - Direct or Indirect